



Northern California 800-221-3667

Southern California 909-596-2090

Portland Oregon 800-359-4197

www.rsdoorproducts.com



About Us

Founded in 1963, R&S Manufacturing, Inc. continues to be a proud manufacturer of rolling door products while remaining mindful of our founding principles of being the “manufacturers with the personal touch”.

Manufacturing plants in Union City, CA. Pomona, CA. and Portland, OR supply a full line of quality rolling door products to customers in markets both domestically and internationally.

R&S Automation supplies motor operators, gate operators and accessories from their three locations – San Leandro, CA. Pomona, CA and Portland, OR.

Commercial and residential sectional doors are provided through R&S Wholesale Doors, Inc. located in San Leandro, California with a distribution office in San Jose.



Products

R&S rolling door products meet the need for secure, effective, space saving closures. A variety of mountings, operation methods, materials, finishes and options are available. Product variations provide for specific requirements such as:

- Weather and Temperature Control
- Ventilation and Visibility
- Access and Egress
- Fire Protection and Smoke Control

Support

Technical and sales support is provided to the R&S dealer network and design professionals. R&S involvement in industry and professional associations includes:

- International Door Association (IDA)
- California Operator and Door Association (CODA)
- Construction Specifications Institute (CSI)
- Northwest Door and Operator Association

Typical Installations

R&S rolling door products are commonly installed on industrial and commercial buildings, military bases, shopping malls, storefronts, schools, hospitals, hotels and parking structures. They have been utilized on projects for:

- Albertsons
- Boeing
- Candlestick Park
- Chevron
- Disneyland
- Fred Meyer
- Hercules
- Hilton
- IBM
- Kennecott
- Lockheed
- Longs Drugs
- Morton Int'l
- Safeway
- UPS

Service Doors

Standard & Optional Features
For Service Doors
& Standard Duty Doors

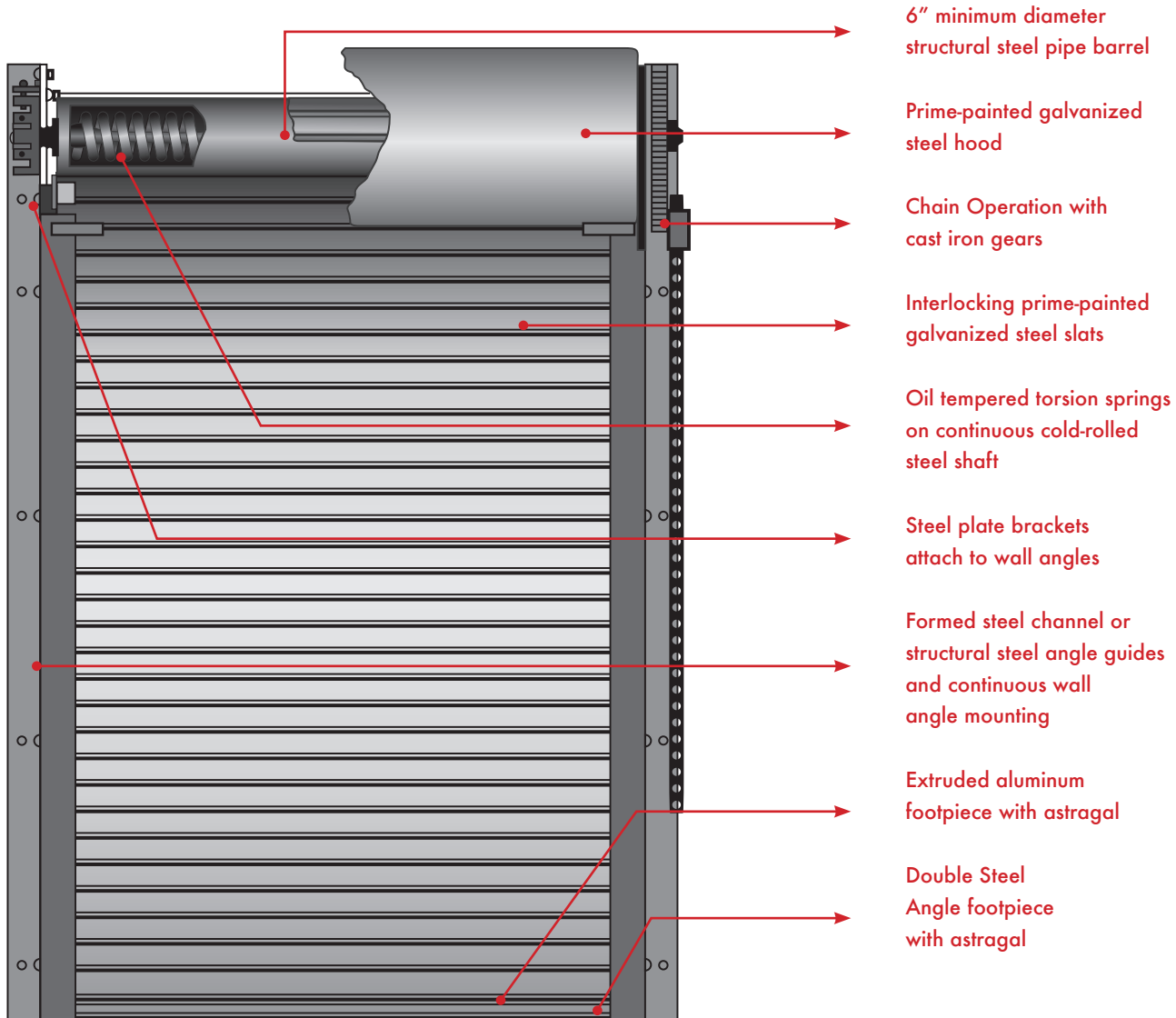

Standard Duty

The R&S Standard Duty door is an economical yet reliable service door.

Climate Guard

Climate control is provided by the combination of a flat slat curtain, hood baffle, guide weatherstripping and astragal.

Heavy Duty

The R&S Heavy Service Duty door provides high security and durability offering years of maintenance free performance.

Thermal Guard

An effective thermal barrier is created by the combination of 22 gage (min.) steel flat faced slats, 3/4" polyurethane foam, and 24 gage steel back slats.

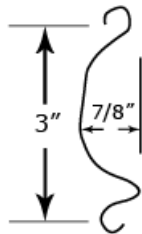

Type 30 Slat:

Standard curved slat for use on all service doors where strength and durability are a consideration. Available in 24, 22, 20, or 18 gage galvanized steel. Also for use on all fire doors.

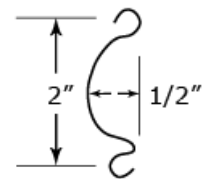

Type 20 Slat:

Optional curved slat for use on Service doors to 16' wide. Available in 22 or 20 gage galvanized steel. Also for use in fire doors to 15' wide.

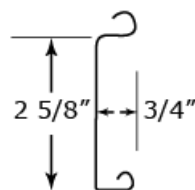

Type 25 Slat:

Standard flat slat for use on all service doors where environmental conditions are a consideration. Available in 24, 22, 20 or 18 gage galvanized steel. Also for use on all fire doors, especially those requiring gasketing.

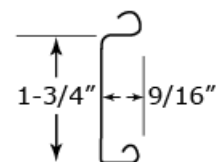

Type 17 Slat

Optional flat slat for use on service doors to 16' wide. Available in 22 or 20 gage galvanized steel or 22 gage stainless steel. Also optional on fire doors to 15' wide. Standard on counter fire doors and counter doors.

Service Doors

Service Door Models

- SD - Standard Duty
- D - Heavy Duty
- W - Climate Guard
- I - Thermal Guard

Specifications

Windload:

- SD,D,W,I - Service doors are designed to withstand a minimum 20 PSF windload.

Warranty:

- SD - One year or 12,500 cycles.
- D,W,I - Two years or 20,000 cycles

Operation:

- SD,D,W,I - Chain hoist is standard; push-up (small sizes), awning crank, crank box or motor operation are optional.

Curtain:

- SD,D,W,I - Galvanized steel slats with baked on gray polyester primer standard. Tan or uncoated galvanized finish available upon request.
- SD - 24 gage slats with stamped steel endlocks.
- D,W - 22,20,18 gage slats, as required to meet windload, with stamped steel endlocks. Windlocks are riveted to slats when required to meet windload.
- I - Same construction as D and W models with the addition of 3/4" laid in place polyurethane or polystyrene foam concealed by 24 gage backslat

Bottom Bar:

- SD,D,W,I - Extruded aluminum footpiece with astragal standard up to 16' wide
- D,W,I - Double steel angle footpiece with astragal standard over 16'. Painted with rust inhibiting black primer.

Guides:

- SD - Steel channels bolted to structural steel wall angles. Painted with rust inhibiting black primer.
- D,W,I - Structural steel angles bolted to structural steel wall angles. Windlock bars are installed when windlocks are required to meet windload. Painted with rust inhibiting black primer.
- W,I - Climate and Thermal-Guard models also include vinyl guide weatherstripping against the flat-faced side of the slats.

Brackets:

- SD,D,W,I - Steel plate brackets are bolted to wall angles to support curtain and barrel, and provide mounting for hood. Painted with rust inhibiting black primer.

Barrel:

- SD,D,W,I - minimum 6" diameter steel pipe houses torsion spring assembly and supports curtain. Torsion springs are mounted on a continuous cold rolled steel shaft, adjustable by a tension wheel on the outside of bracket.

Hood:

- SD,D,W,I - Formed 24 gage galvanized steel sheet, with baked on gray polyester primer reinforced with top and bottom flanges to limit deflection. Intermediate support is provided when required.
- W,I - Internal rubber baffle hangs against curtain to reduce air infiltration.

Locking:

- SD,D,W,I - Chain lock with chain operation and slidebolt locks with push-up or crank operation standard.

Options

Increased Windload Capacity:

Curtain designs to withstand windloads exceeding 20 PSF.

High Cycle Construction:

Designs to provide up to 150,000 operating cycles or maximum possible design.

Perforated Slats:

3/64" diameter holes on 5/64" staggered centers in type 25 slats provide 30% open area for ventilation and visibility throughout the curtain.

Vision Lites:

Single or multiple 3" wide cut-outs, open for ventilation or covered with acrylic.

Powder Coat Finish:

Powder Coating available on all exposed surfaces.

Galvanized Finish:

Hot dip Galvanizing available on footpiece, guides and brackets

Intermediate Grille:

Partial grille curtain connecting slats above and below.

Sloped Footpiece:

For door openings on a slope.

Cylinder Locks:

Key or finger-throw cylinder installed on footpiece for easy secure locking.

Pass Door:

3'-0" x 7'-0" x 1-3/4" thick hollow metal gray primed (black optional) door in a steel frame for access through the curtain when closed; frame is hinged to guide and swings clear to allow use of entire door opening when curtain is raised.

Mounting Details

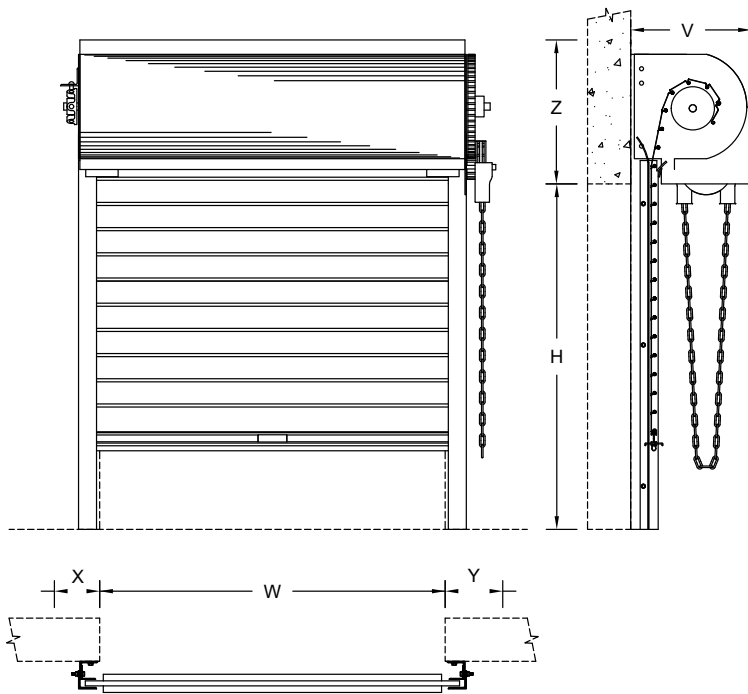

Standard Clearance Requirements

Area	Z"	V"
A	20	16 3/4
B	22	17
C	23 1/2	18 1/2
D	25 1/2	20 1/2
E	29 1/2	24 1/2
F	Consult Factory	

Opening width 'W'	X"	Y"
Thru 15'	6	8
Over 15' Thru 24'	7	8

R/H chain operation as shown - reverse
'X' and 'Y' for L/H

Reduce 'Z' by 2" with top hood flange turned down

Large Flat (#25)

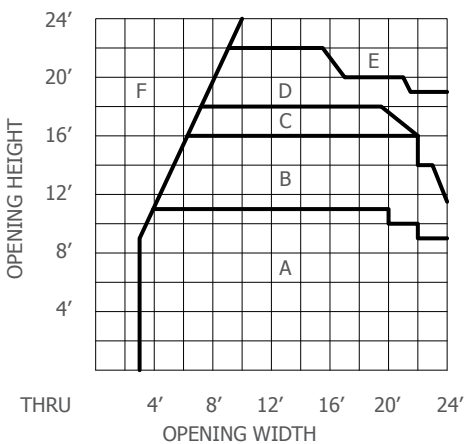

Large Curve (#30)

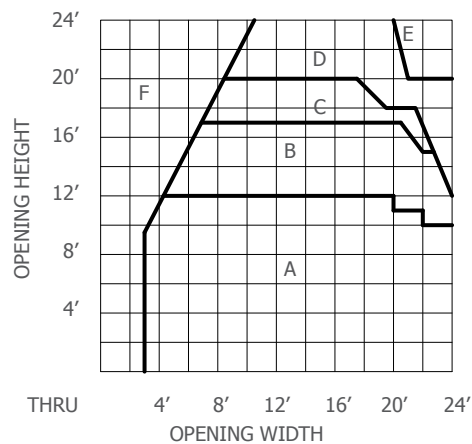

Insulated (Thermal-Guard)

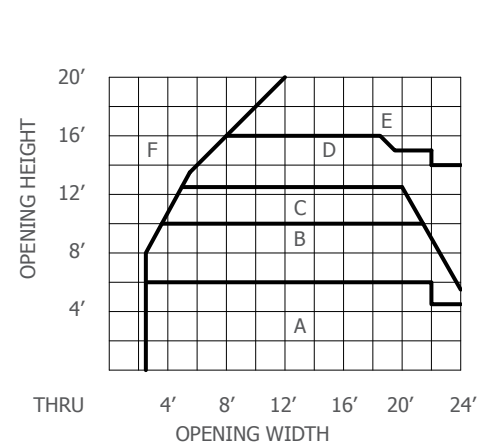

Fire Doors

Model R

R&S Fire Doors combine the durability, security, efficiency and space saving advantages of a rolling service door with the added life and property saving benefits of automatic fire protection Warnock Hersey Label is furnished standard.

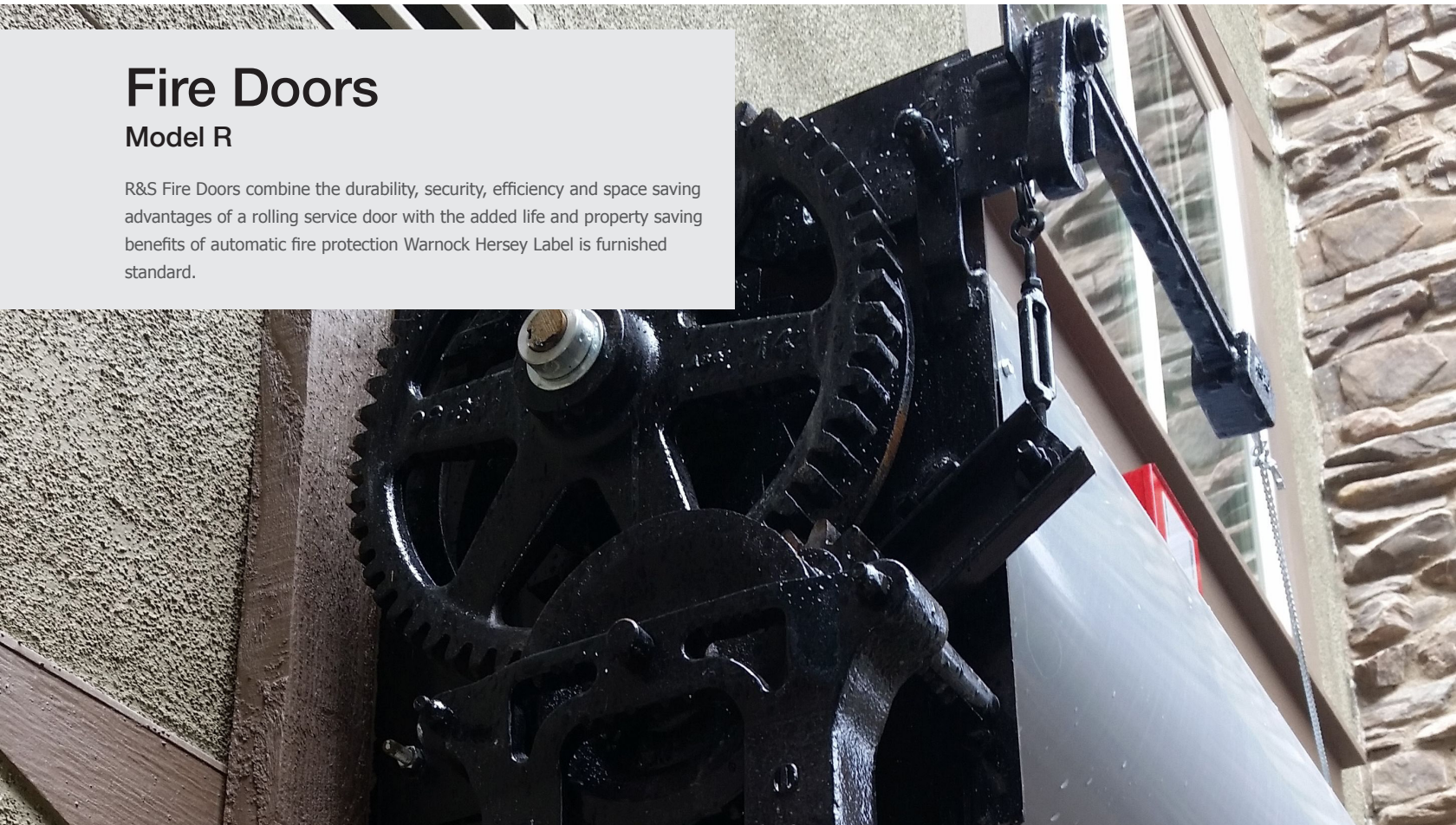

Specifications

Warranty:

Two years or 20,000 cycles

Mounting:

Face of wall or between-jamb

Operation:

Push-up to 8' wide and high and chain hoist on larger sizes is standard; awning crank, crank box or motor operation are optional.

Automatic Closing:

Thermally activated by 165° fusible links, with the closing speed regulated by a governor device operative only during automatic closing.

Curtain:

Galvanized steel slats are 22, 20 or 18 gage, as required for size, with baked on gray polyester primer standard and stamped steel endlocks. Tan or uncoated galvanized finish available upon request.

Bottom Bar:

Double steel angle footpiece with slotted assembly holes and fiber washers allow for expansion to meet listing. Painted with rust inhibiting black primer.

Guides:

Steel structural steel angles form curtain guides and are bolted to structural steel wall angles. Slotted assembly holes and fiber washers allow for expansion to meet listing. Painted with rust inhibiting black primer.

Options

LiftMaster Release Devices:

See Fire Door accessories page.

Smoke Detectors:

Photoelectric (detects smoke and heat) require connection to a release device (XPBB) or FDC Operator.

Perimeter Gasketing:

Brush seals factory applied to guides and footpiece, field installed on header, to aid in smoke and draft control.

Slide Locks:

Manual throw slide locks mounted to bottom bar available when non-standard for added security.

Powder Coat Finish:

Available on all exposed surfaces

Galvanized Finish:

Hot dip Galvanizing available on footpiece, guides and brackets

Testing Agency



Warnock Hersey



Underwriters Laboratories

File Number

R-9560

R-9560

Hourly Rating

1 1/2 Hour Sheetrock/ 3 Hour Masonry

3 Hour

Wall Construction

Drywall or Masonry

Masonry

Jamb Type

16 ga. (min) Steel Stud
Steel Tube, Wood Stud,
Concrete, Block Brick

Concrete
Block
Brick

Label size

12' Wide
12' High
120 Sq. Ft. Max

12' Wide
12' High
120 Sq. Ft. Max

Oversize

24' Wide
24' High
576 Sq. Ft. Max.

24' Wide
24' High
576 Sq. Ft. Max.

Jamb must be continuous members from floor to structure above. Sizes and attachment of members is to be determined to provide adequate mounting and support for the size and weight of the door.

Standard Clearance Requirements



Area	Z"	V"
A	21 3/4	20
B	23 1/4	21 1/2
C	25 1/4	23 1/2
D	29 1/4	27 1/2
E	Consult Factory	

1. Additional clearance may be required for #25 slat
2. Additional Clearance may be required when brackets mount above a ceiling
3. Reduce 'Z' by 2" with top hood flange turned down

Opening width 'W'	X"	Y"
Thru 8'	6 5/8	9
Over 8' Thru 12'	7 1/8	9 1/2
Over 12' Thru 15'	7 1/2	10
Over 15' Thru 18'	9 1/2	10 1/2
Over 18' Thru 24'	10 1/2	11 1/2

R/H chain operation as shown - reverse 'X' and 'Y' for L/H

Mounting Details

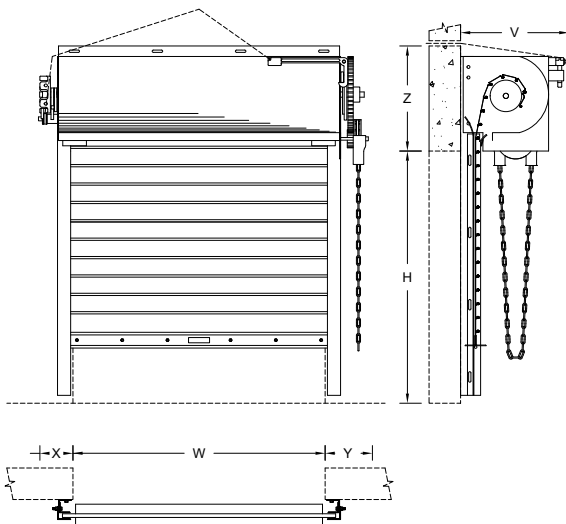

Model Designation

By Method of Operation

Face of Wall Mount

- RFP - Push-Up
- RFC - Chain
- RFT - Thru-wall chain
- RFA - Awning Crank
- RFB - Crank Box
- RFM - Motor

(For Between-Jamb Mount, change letter 'F' to 'J'.)

Fire doors are to be installed by an R & S authorized representative in accordance with R & S installation instructions and NFPA 80.

Fire doors are to be drop tested and witnessed for proper operation and full closure after installation.

NFPA-80 and model code groups mandate annual inspection and testing of fire doors to check for proper operation and full closure.

Fire Door Accessories



Grifco Fire Door Chain Hoist

Fire Door Release Devices

Model LM21XPBB: For Use as a Stand-alone Localized Fire Alarm System

Versatility allows the XPBB release device to operate on 120VAC, 24VAC, or 24VDC power sources. Internal Battery Backup allows the release device to stand-alone from the fire alarm system and act independently in the event of a power outage. The system can provide 24VDC power for up to 4 smoke detectors and 2 horn strobes, mounted on either side of the door. Programmable delay settings, close door detection, diagnostic LEDs, localized testing and reset capabilities are all also standard.

Features include:

- UL864 Revision 9 Compliant
- Programmable DIP Switch delay setting - either 10, 20, 30, or 60 seconds delay of door release to permit passage clearance
- Inputs for normally open 2- or 4-wire detectors and 4-wire normally closed detectors
- Trouble and alarm relays for communication with the fire alarm control panel, if required
- Audible trouble sounder to indicate when the release device is not operational
- On board diagnostic LEDs for easy troubleshooting
- Testing function allows routine fire door testing without requiring activation of the smoke detector

Model LM21XP: For use as an Interface Between Central Alarm System and Door

The XP release device provides a fail-safe release mechanism for non-motorized doors and acts as an interface between the door and fire alarm system. The device requires 24VDC power from an approved UL1481

regulated power supply with Battery Backup, such as a fire alarm control panel. Therefore, installation will require coordination with a fire panel installer.

Features include:

- UL864 Revision 9 Compliant
- Programmable DIP Switch delay setting –Either 10, 20, 30, or 60 seconds delay of door release to permit passageway clearance
- Close door detection – Prevents door release if the door is kept in the closed position and eliminates door reset service calls or potential system damage
- On board diagnostic LEDs for early troubleshooting
- Testing function allows routine fire door testing without requiring activation of the
- Central alarm system; easy reset function returns the device to a standby state

Release Device Accessories

Voice Board

A solid-state speech module for the XPBB. In an alarm condition, the VB will provide a warning tone followed by a voice message/ warning prior to door closure. The VB can be used with up to 2 speaker strobes or stand-alone speakers.

Smoke Detectors

Smoke detectors are available in Photoelectric, Photo-thermal, or Ion types; can be powered off the XPBB and used to provide a local alarm signal that activates the release device.



LM21XPBB Release Device



FDCL Light Duty Fire Door Operator



VIBRATECH VISCOUS GOVERNOR

Liftmaster Fire Door Operators

FDC & FDCL Light Duty

- Time delayed automatic closing
- Auto-reset Overload protection
- Monitored battery back-up
- Low battery warning
- Programmable closing function selections
- Keyed test station
- Electronic thermal sensors (field installed)
- Continuous duty motor
- Detector/alarm input
- Adjustable linear driven limit switches
- 24-volt control Circuit
- 3-button open/close/stop control station
- NEMA 1 enclosures
- UL Listed
- Provides automatic closing without a loss of spring tension – eliminates the need for traditional mechanical reset
- Electronic thermal sensor, detector or alarm activation of motor controlled closing or internal release and brake controlled closing
- Provision for optional remote fusible link release connection
- 72 hour (FDC), 2 hour (FDCL) battery backup with automatic closing prior to complete discharge of batteries
- Close on alarm feature to close door through motor operator upon activation by thermal sensor, detector or alarm – will activate warning device (if provided), and close door after selectable time delay. If an obstruction is encountered, it will cycle upon contact and/or stop on the obstruction, internally release and continue to close when the obstruction is removed with the closing speed controlled through the brake (requires door be provided with a sensing edge) -Automatic closing upon power loss

- prior to battery discharge – will activate devices (if provided), internally release and close door after selectable time delay with closing speed controlled by the brake. If an obstruction is encountered, the door will stop on the obstruction and continue to close after it is removed (requires door be provided with a sensing edge)
- Failsafe closing in the event of system failure – will internally release and close door with controlled descent
- Auto-reset to restore normal operation of door by activating open control after alarm is cleared/power is restored
- ½ and 1HP (FDC), ½HP (FDCL)
- 115V, 230V-1PH / 208-230V, 460V-3PH

VIBRATECH ® Viscous Speed Governor

VIBRATECH ® Viscous Speed Governor for a smooth and quiet descent of fire doors, replaces standard ductile iron governor. Viscous speed governor is U.L. listed and conforms to ASTM E152, CAN4-S104, NFPA 252, and UL 10B. Simple, maintenance-free design and construction, with a one year warranty.

Grifco

The Grifco Manual Fire Door Hoist has been developed to allow the safe emergency closing of rolling fire doors.

The system allows manual use of the rolling door during normal circumstances. The hoist is connected to the fusible link chain and release device if equipped. The chain is also routed through a test lever mounted to the guide. This allows the door to be tested by simply releasing the lever. After the door has done its controlled descent via the adjustable centrifugal brake, the lever is reset and the door can be operated as normal.

Counter Fire Doors

Models:

L Steel Counter Door

SL Stainless Steel Counter Fire Door

R&S Counter Fire Doors integrate the automatic fire protection of a Rolling Fire Door with the compact design and neat appearance of a Counter Door. They are available in Primed Steel or Stainless Steel and have most of the same options as Fire Doors. Warnock Hersey Label is furnished standard.

Specifications

Warranty:

Two years or 12,500 cycles

Mounting:

Face of wall or between-jamb

Operation:

Push-up to 12' wide and awning crank on larger sizes is standard (awning crank should be considered when doors are to be operated over a deep counter of over 7' high). Chain hoist or motor operation are optional.

Automatic Closing:

Thermally activated by 165° fusible links, with the closing speed regulated by a governor device operative only during automatic closing.

Curtain:

Interlocking type 17 flat slats are roll formed from (galvanized steel) (stainless steel – 12' max. width) coil. Gage of slats is as required by the listing.

Bottom Bar:

Single steel angle footpiece with slotted assembly holes and fiber washers allow for expansion to meet listing.

Guides:

Box shape guides are formed from (steel) (stainless steel). Slotted assembly holes and fiber washers allow for expansion. Depth of guides are as required by the listing.

Brackets:

Steel plate brackets are bolted to guides to support curtain and barrel and provide mounting for hood.

Barrel:

Steel pipe houses torsion spring assembly and supports curtain with a maximum deflection of .03 inch per foot of width. Torsion springs are mounted on a continuous cold rolled steel shaft, adjustable by a tension wheel outside one bracket.

Hood:

Square hood formed from 24 gauge (galvanized steel) (stainless steel) sheet, reinforced with top and bottom flanges to limit deflection.

Locking:

Slide Bolt locks standard for push-up operation, optional otherwise.

Curtain Details

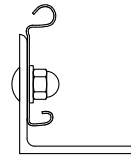

Single Angle Footpiece

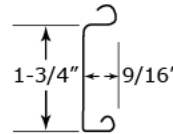

#17 Slat

Guide Details

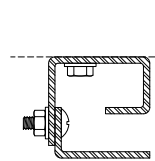

Face Mount

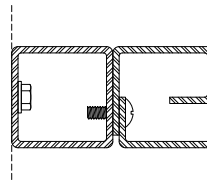

Between-Jamb Mount

Finish:

Galvanized steel slats and hoods are pre-finished with a baked on gray polyester primer before forming (Tan or bare available upon request). Steel footpiece, guides and brackets receive one coat of rust inhibiting color matching primer. Exposed stainless steel provided with #4 finish.

Options

Grifco or FDCL:

Grifco Fire Door Chain Hoist and Liftmaster FDCL Fire Door Motor, provide smooth automatic closing without tension loss, saving time and money on testing and resetting.

LiftMaster Release Devices

Smoke Detectors: Photoelectric (detects smoke and heat) require connection to a release device (XPBB) or FDC Operator.

Perimeter Gasketing:

Brush seals factory applied to guides and footpiece, field installed on header, to aid in smoke and draft control.

Cylinder Locks:

Key or thumbturn cylinder lock installed on footpiece for added security and convenience.

Powder Coat Finish:

Available on all exposed surfaces

Galvanized Finish:

Hot dip Galvanizing available on footpiece, guides and brackets

Testing Agency



Warnock Hersey



Underwriters Laboratories

File Number

WHI-495-0968

R-9560-2

Hourly Rating

1 1/2 Hour Sheetrock/ 3 Hour Masonry

3 Hour

Wall Construction

Drywall or Masonry

Masonry

Jamb Type

16 ga. (min) Steel Stud
Steel Tube, Wood Stud,
Concrete, Block Brick

Concrete
Block
Brick

Label size

12' Wide
9' High
72 Sq. Ft. Max

12' Wide
7' High
84 Sq. Ft. Max

Oversize

15' Wide
10' High
96 Sq. Ft. Max.

15' Wide
7' High
84 Sq. Ft. Max.

Jamb must be continuous members from floor to structure above. Sizes and attachment of members is to be determined to provide adequate mounting and support for the size and weight of the door.

Standard Clearance Requirements

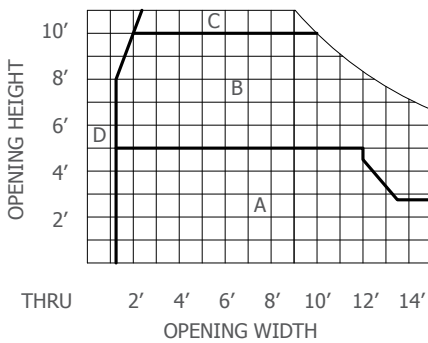

Area	Z"	V"
A	12	10 1/2
B	14	12 1/2
C	15	13 1/2
D	Consult Factory	

1. Additional clearance may be required when brackets mount above ceiling
2. Crank bracket extends 5" past 'V' dimensions

Opening width 'W'	X"	Y"
Thru 8'	4 1/4	4 1/4
Over 8' Thru 15'	5 1/8	5 1/8

1. Add 1" to 'Y' for crank operation
2. Add 3/4" to 'X' and 'Y' for doors thru 8'0" wide face mount to masonry jamba
3. Reduce 'X' and 'Y' by 1/4" for Between-Jamb Mount

R/H chain operation as shown
- reverse 'X' and 'Y' for L/H

Mounting Details

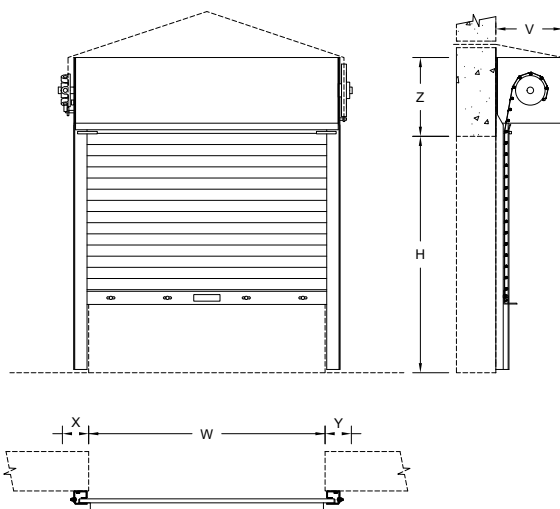

Model Designation

By Method of Operation

Face of Wall Mount

- LFP - Push-Up
- LFA - Awning Crank
- LFC - Chain
- LFM - Motor

(For Between-Jamb Mount, change letter 'F' to 'J')

Fire doors are to be installed by an R & S authorized representative in accordance with R & S installation instructions and NFPA 80.

Fire doors are to be drop tested and witnessed for proper operation and full closure after installation.

NFPA-80 and model code groups mandate annual inspection and testing of fire doors to check for proper operation and full closure.

Counter Doors

Models:

N Steel Counter Doors

SN Stainless Steel Counter Doors

R&S Steel and Stainless Steel Counter Doors combine the strength and durability of a rolling service door with compact design and neat appearance. Although primarily used as a closure on counter openings, it may also be used on openings providing walk-thru or drive-thru access.



Specifications

Warranty:

Two years or 12,500 cycles

Mounting:

Face of wall or between-jamb

Operation:

Push-up to 14' wide and awning crank on larger sizes is standard (awning crank should be considered when doors are to be operated over a deep counter of over 7' high). Chain hoist or motor operation are optional.

Curtain:

Interlocking type 17 flat slats are roll formed from 22 gage (galvanized steel) (stainless steel) coil. With a single angle Bottom Bar

Guides:

Box shape guides are formed from (steel) (stainless steel).

Brackets:

Steel plate brackets are bolted to guides to support curtain and barrel and provide mounting for hood.

Barrel:

Steel pipe houses torsion spring assembly and supports curtain with a maximum deflection of .03 inch per foot of width. Torsion springs are mounted on a continuous cold rolled steel shaft, adjustable by a tension wheel outside one bracket.

Hood:

Square hood formed from 24 gauge (galvanized steel) (stainless steel) sheet, reinforced with top and bottom flanges to limit deflection.

Locking:

Slide Bolt locks standard for push-up operation, optional otherwise.

Finish:

Galvanized steel slats and hoods are pre-finished with a baked on gray polyester primer before forming (Tan or bare available upon request). Steel footpiece, guides and brackets receive one coat of rust inhibiting color matching primer. Exposed stainless steel provided with #4 finish.

Options

Powder Coat Finish:

Available on all exposed surfaces

Galvanized Finish:

Hot dip Galvanizing available on footpiece, guides and brackets

Increased Windload Capacity:

Curtain designs to withstand wind loads exceeding 20PSF.

High Cycle Construction:

Designs to provide up to 50,000 operating cycles or maximum possible in design.

Vision Lites:

Single or multiple 3" wide cutouts, open for ventilation or covered with acrylic.

Sloped or Stepped Footpiece:

To accommodate special sill conditions.

Cylinder Locks:

Key or thumbturn cylinder lock installed on footpiece or guide for added security and convenience.

Galvanized Finish:

Hot dip galvanizing on footpiece, guides and brackets.

Tubular Motor Operator:

Mounting Details

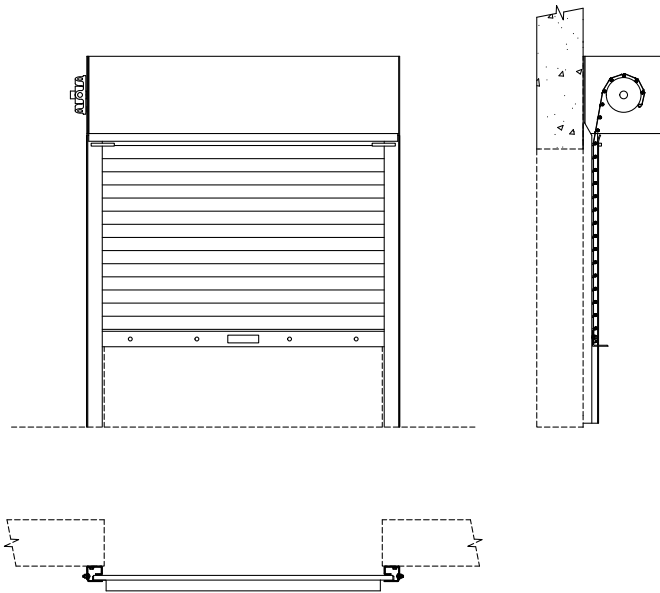

Tubular Motor Operator:

Motors completely contained within the barrel can be provided for counter doors in limited usage applications. Only the manual crank override is visible outside the bracket.

The units are available in 115 volt/ single phase with constant contact one button or key switch control. They can also be provided with a low voltage controller when options such as a 3 button station, reversing edge or timer are required.



Curtain Details

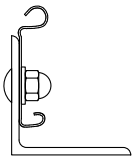

Single Angle Footpiece

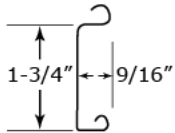

#17 Slat

Guide Details

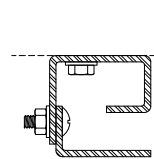

Face Mount

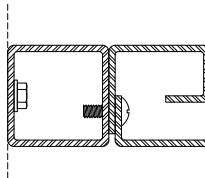

Between-Jamb Mount

Standard Clearance Requirements

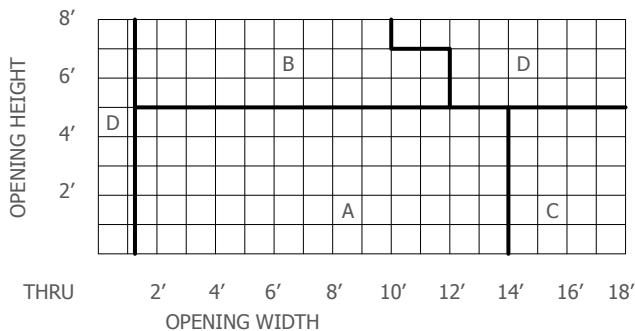

Area	Head Room	Tension Sideroom	Power Sideroom	
			Push-up	Crank
A	12"	4 1/4"	2 1/4"	4 1/4"
B	14"	4 1/4"	2 1/4"	4 1/4"
C	12"	4 1/4"	—	4 1/4"
D	Consult Factory			

1. Reduce Sideroom by 1/4" for Between-Jamb Mount
2. Reduce Tension Sideroom by 2" with inside tension (Standard on between-jamb mount, available on face mount)

Aluminum Counter Doors

Model S

R&S Aluminum Counter Doors offer compact design and attractive appearance. Anodized extruded aluminum components are lightweight and have a smooth, bright finish that has excellent corrosion resistance.



Specifications

Warranty:

Two years

Mounting:

Face of wall or between-jamb

Operation:

Push-up standard (awning crank should be considered when doors are to be operated over a deep counter of over 7' high). Chain hoist or motor operation are optional.

Curtain:

Interlocking type 15 flat slats are extruded from 6063 alloy aluminum. Bottom of curtain is reinforced by an extruded aluminum tubular footpiece.

Guides:

Extruded aluminum guides are bolted to aluminum wall angles. Guides are fitted with nylon pile wear strips.

Brackets:

Steel plate brackets are bolted to guides to support curtain and barrel and provide mounting for hood.

Barrel:

Steel pipe houses torsion spring assembly and supports curtain with a maximum deflection of .03 inch per foot of width. Torsion springs are mounted on a continuous cold rolled steel shaft, adjustable by a tension wheel outside one bracket.

Hood:

Square hood formed from aluminum sheet, reinforced with top and bottom flanges to limit deflection.

Locking:

Slide Bolt locks standard for push-up operation, optional otherwise.

Finish:

Aluminum slats, footpiece, guides and hood are clear anodized. Steel brackets receive one coat or rust inhibiting gray primer. (Dark bronze and other color anodized finishes are optional.)

Options

Cylinder Locks:

Key or thumbturn cylinder lock installed on footpiece or guide for added security and convenience.

Finish:

Standard clear anodized finish may be upgraded to dark bronze or black

Tubular Motor Operator:

Motors completely contained within the barrel can be provided for counter doors in limited usage applications. Only the manual crank override is visible outside the bracket.

Mounting Details

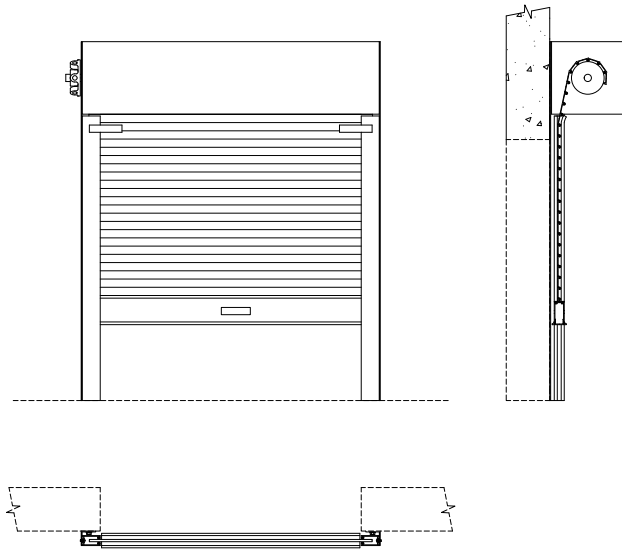

Curtain Details

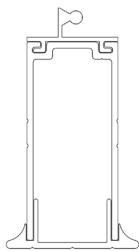

Extruded Aluminum Tubular
Bottom Bar

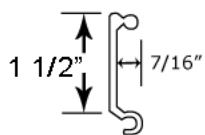

#17 Slat

Guide Details

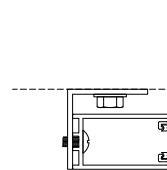

Face Mount

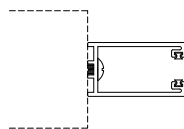

Between-Jamb Mount

Standard Clearance Requirements

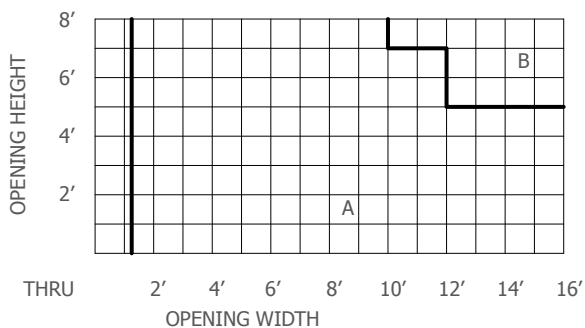

Area	Head Room	Tension Sideroom	Power Sideroom	
			Push-up	Crank
A	13 1/2"	4 3/4"	2 3/4"	4 3/4"
B	Consult Factory			

1. Reduce Sideroom by 1/4" for Between-Jamb Mount
2. Reduce Tension Sideroom by 2" with inside tension

Aluminum Grilles

Model G



Specifications

Warranty:

- Standard Duty: One year or 12,500 cycles.
- Heavy Duty: Two years or 20,000 cycles

Mounting:

Face of wall or between-jamb.

Operation:

Push-up to 14' wide and 9' high and chain hoist on larger sizes is standard. Awning crank, crank box or motor operation are optional.

Curtain:

Formed with horizontal rods 1 1/2" apart, connected by vertical links 9" apart. Bottom of curtain is reinforced by an extruded aluminum tubular footpiece.

Guides:

Extruded aluminum guides are bolted to structural steel wall angles. Guides are fitted with nylon pile wear strips.

Brackets:

Steel plate brackets are bolted to wall angles to support curtain and barrel and provide mounting for hood.

Barrel:

Steel pipe houses torsion spring assembly and supports curtain with a maximum deflection of .03 inch per foot of width. Torsion springs are mounted on a continuous cold rolled steel shaft, adjustable by a tension wheel outside or inside one bracket.

Locking:

Slidebolt locks with push-up or crank operation and chain lock with chain operation.

Finish:

Aluminum curtain, footpiece and guides are mill finish. Steel brackets and wall angles receive one coat or rust inhibiting black primer.

Options

Support Tubes:

Measuring 4"x4" or 3"x3" support tubes are attached to floor and structure above to provide mounting for grille.

Sloped Bottom Section:

For door openings on a slope

Soffit Flange Cover:

Measuring 5 1/2" wide affixed to footpiece bottom is used conceal slot required for above ceiling installations.

Cylinder Locks:

Key or thumbturn cylinder lock installed on footpiece for added security and convenience.

Hood Options:

Galvanized steel or aluminum sheet metal is offered.

Fixed Grille Panels:

Offered in situations where the opening is larger than the door. A static grille curtain is supported by a frame and secures the opening beyond the rolling grille section while providing a continuity in appearance.

Anodized Finishes:

Offered include clear, dark bronze, gold and black on curtain, footpiece, guides and hood.

Tubular Motor Operator:

Motors completely contained within the barrel can be provided for grilles up to 200 sq ft in limited usage applications. Only the manual crank override is visible outside the bracket.

Emergency Egress System:

Recessed pull handle is provided in a flush mounted enclosure to mechanically disconnect motor operator allowing a partial grille opening for egress.

High Cycle Construction:

Offered under certain conditions to provide up to 150,000 operating cycles.

Curtain Details

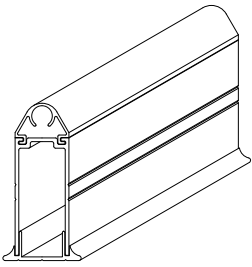

Extruded Aluminum Tubular Bottom Bar

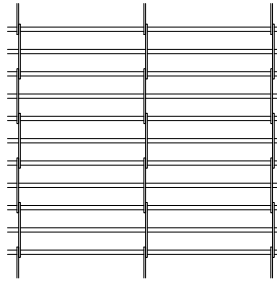

Standard Straight Link Pattern

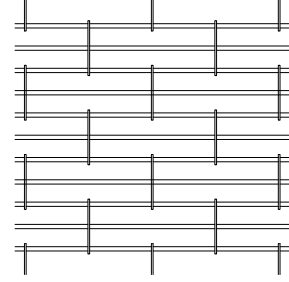

Optional Brick Pattern

Guide Details

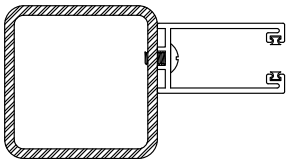

Tube Mount

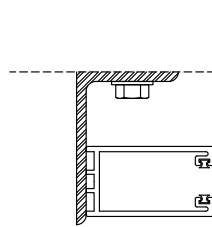

Face Mount

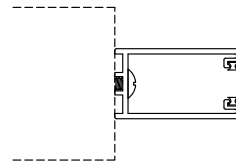

Between-Jamb Mount



Mounting Details

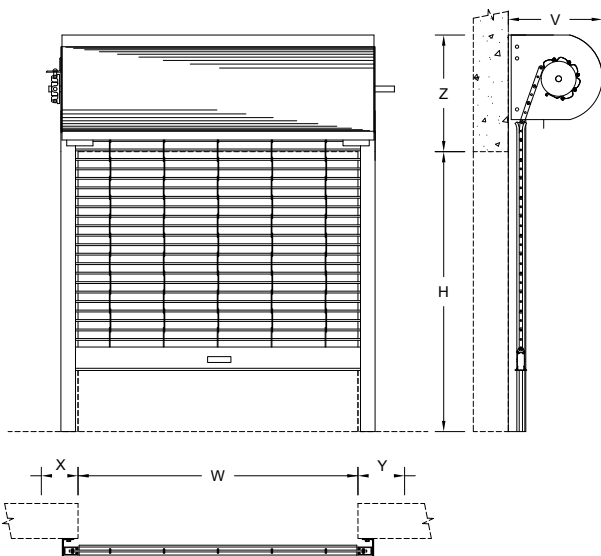

Standard Clearance Requirements

Operation	W	H	X"	Y"	Z**	V**
Push-Up	To 14'	To 9'	6	6	20	15
Chain	To 16'	To 9'	6	8	20	15
Or	To 16'	9'-14'	6	8	22	17
Crank	16'-24'	To 8'	6	8	20	15
	16'-24'	8'-14'	6	8	22	17
Motor	Consult Factory					

R/H Operation as shown - reverse 'X' & 'Y' for L/H



Rolling Doors and Grilles

R&S Manufacturing of Northern CA

P.O. Box 2737
33955 7th St., Union City, CA 94587-7737
800-221-3667
510-429-1788
Fax: 510-429-1172

R&S Manufacturing of Southern CA

283 West Bonita, Pomona, CA 91767
800-350-3667
909-596-2090
Fax: 909-596-3050

R&S Manufacturing Oregon

7200 South East 92nd Unit B, Portland, OR 97266
800-359-4197
503-777-6370
Fax: 503-777-6394

Web

www.rsdoorproducts.com

R&S Automation

R&S Automation of Northern CA

2041 West 140th Avenue, San Leandro, CA 94577
800-543-6001
510-357-4110

R&S Automation of Southern CA

283 West Bonita, Pomona, CA 91767
714-449-1645

R&S Automation Oregon

7200 South East 92nd Unit A, Portland, OR 97266
877-388-4001

Web

www.rsoperators.com